

### 卡式內徑測微器(經濟型)

- 解析度: 0.01mm
- 棘輪測力
- 硬質合金測量面
- 可選附件: 校對環規(型號6312), 測微器固定座和夾持塊(型號6301和6301-1)

型號	測定範圍	類型	校對環規	精度	金額
3220-30	5-30mm	A	5mm(標配)	7 $\mu$ m	3355.00
3220-50	25-50mm	B	25mm(標配)	8 $\mu$ m	3906.00
3220-75	50-75mm	B	50mm(選配)	9 $\mu$ m	4354.00
3220-100	75-100mm	C	75mm(選配)	10 $\mu$ m	5290.00

測微器固定座  
配夾持塊(選配)



3220-50

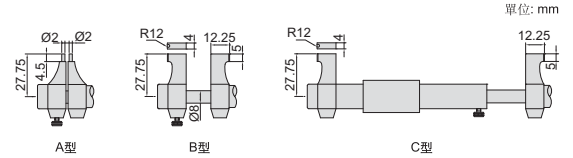

單位: mm

### 卡式數位內徑測微器(經濟型)

- 解析度: 0.001mm/0.00005"
- 按鍵: 開/關, 初始值設置, 公/英制轉換, 數據輸出
- 數據傳輸, 自動關機
- 棘輪測力, 硬質合金測量面
- 可選附件: 數據連接線(型號7315-31需選配接收部, 7302-31), 校對環規(型號6312)

型號	測定範圍	類型	校對環規	精度	金額
3520-30	5-30mm/0.2-1.2"	A	5mm(標配)	$\pm 5\mu$ m	9110.00
3520-50	25-50mm/1-2"	B	25mm(標配)	$\pm 6\mu$ m	10344.00
3520-75	50-75mm/2-3"	B	50mm(選配)	$\pm 7\mu$ m	13258.00
3520-100	75-100mm/3-4"	C	75mm(選配)	$\pm 8\mu$ m	13864.00



3520-30

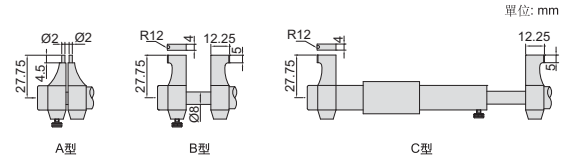

單位: mm

數據  
傳輸

### 管狀內徑測微器

- 微分頭測定範圍: 50-63mm
- 解析度: 0.01mm
- 精度:  $(3+n+L/50)\mu$ m  
n=延長杆數量, L=最大測量長度(mm)
- 配校對規
- 硬質合金測量面

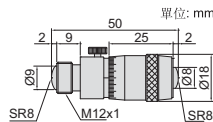

型號	測定範圍	微分頭行程	延長杆	金額
3222-150	50-150mm	13mm	13mm, 25mm, 50mm	3858.00
3222-300	50-300mm	13mm	13mm, 25mm, 50mm(2個), 100mm	4836.00
3222-500	50-500mm	13mm	13mm, 25mm, 50mm(2個), 100mm, 200mm	6198.00
3222-600	50-600mm	13mm	13mm, 25mm, 50mm, 100mm, 150mm, 200mm	7965.00
3222-1000	50-1000mm	13mm	13mm, 25mm, 50mm(2個), 100mm, 200mm(2個), 300mm	10818.00
3222-1500	50-1500mm	13mm	13mm, 25mm, 50mm(2個), 100mm, 200mm(3個), 300mm(2個)	14325.00



3222-150

### 管狀數位式內徑測微器

- 微分頭測定範圍: 150-175mm
- 硬質合金測量面
- 解析度: 0.001mm/0.00005"
- 精度:  $(3+n+L/50)\mu$ m  
n=延長杆數量, L=最大測量長度(mm)
- 延長杆外圓尺寸 $\varnothing 22$ mm
- 測微頭防塵/防水等級: IP65
- 按鍵: 開/關, 初始值設置, 公/英制轉換, 數據輸出
- 數據傳輸, 自動關機, 配校對規
- 可選附件: 數據連接線(型號7315-31需選配接收部, 7302-31)



3521-1000

型號	測定範圍	微分頭行程	延長杆	金額
3521-175	150-175mm	25mm	—	14572.00
3521-1000	150-1000mm	25mm	25mm, 50mm(2個), 100mm, 200mm, 400mm	25887.00

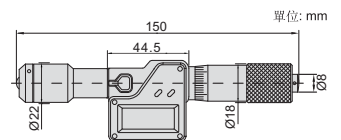

單位: mm

IP65  
防塵防水

數據  
傳輸

### 管狀內徑測微器

- 解析度: 0.01mm
- 精度: (6+L/50) $\mu$ m  
L=最大測量長度(mm)
- 可選附件: 校對環規(6312系列), 量塊附件(6881系列), 圓柱量塊(4001系列), 卡尺/高度計檢測規(6884系列)



3221-50

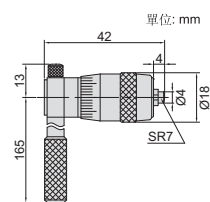

型號	測定範圍	微分頭行程	延長杆	金額
3221-50	25-50mm	7mm	2個	4281.00
3221-300	50-300mm	13mm	10個	6326.00

### 兩點/三點式內徑測微器



3227-8

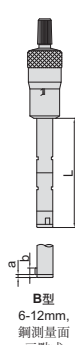

B型  
6-12mm,  
鋼測量面  
三點式



3227-16

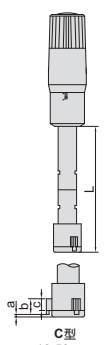

C型  
12-50mm,  
硬質合金測量面  
三點式



3227-100

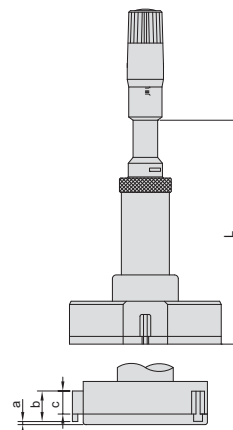

D型  
50-200mm,  
硬質合金測量面  
三點式

- 符合DIN863-4
- 6-12mm解析度為0.001mm, 12-200mm解析度為0.005mm
- 棘輪測力
- 可選附件: 校對環規(型號6312), 測微器固定座和夾持塊(型號6301和6301-2)

#### 單支

型號	測定範圍	類型	精度	校對環規	延長杆(標配)	L	a	b	c	金額
3227-8*	6-8mm	B(三點)	4 $\mu$ m	Ø6(標配)	100	54.5	1.5	2.5	—	9161.00
3227-10*	8-10mm	B(三點)	4 $\mu$ m	Ø8(標配)	100	54.5	1.5	2.5	—	9161.00
3227-12*	10-12mm	B(三點)	4 $\mu$ m	Ø10(標配)	100	54.5	1.5	2.5	—	9161.00
3227-16*	12-16mm	C(三點)	4 $\mu$ m	Ø16(標配)	150	80	0.5	6	4.5	8367.00
3227-20*	16-20mm	C(三點)	4 $\mu$ m	Ø16(標配)	150	80	0.5	6	4.5	8369.00
3227-25*	20-25mm	C(三點)	4 $\mu$ m	Ø25(標配)	150	90	0.5	8	6	9577.00
3227-30*	25-30mm	C(三點)	4 $\mu$ m	Ø25(標配)	150	90	0.5	8	6	9579.00
3227-40*	30-40mm	C(三點)	4 $\mu$ m	Ø40(標配)	150	97	0.5	14	12	10615.00
3227-50*	40-50mm	C(三點)	5 $\mu$ m	Ø40(標配)	150	97	0.5	14	12	10890.00
3227-63*	50-63mm	D(三點)	5 $\mu$ m	Ø62(標配)	150	114	0.5	17.5	14.5	11912.00
3227-75*	62-75mm	D(三點)	5 $\mu$ m	Ø62(標配)	150	114	0.5	17.5	14.5	12737.00
3227-88*	75-88mm	D(三點)	5 $\mu$ m	Ø87(標配)	150	114	0.5	17.5	14.5	13324.00
3227-100*	87-100mm	D(三點)	5 $\mu$ m	Ø87(標配)	150	114	0.5	17.5	14.5	13834.00
3227-125*	100-125mm	D(三點)	6 $\mu$ m	選配	150	140	0.9	29	25	19800.00
3227-150*	125-150mm	D(三點)	6 $\mu$ m	選配	150	140	0.9	29	25	23580.00
3227-175*	150-175mm	D(三點)	7 $\mu$ m	選配	150	140	0.9	29	25	24137.00
3227-200*	175-200mm	D(三點)	7 $\mu$ m	選配	150	140	0.9	29	25	27454.00

測微器固定座配夾持塊(選配)



校對環規



6-100mm標配環規  
100-200mm不配環規, 需另購

延長杆(標配)



#### 套裝

型號	測定範圍	包含的測微器	校對環規(標配)	延長杆(標配)	金額
3227-123*	6-12mm	6-8mm, 8-10mm, 10-12mm	Ø6mm, Ø8mm, Ø10mm	100mm	28631.00
3227-202*	12-20mm	12-16mm, 16-20mm	Ø16mm	150mm	16568.00
3227-504*	20-50mm	20-25mm, 25-30mm, 30-40mm, 40-50mm	Ø25mm, Ø40mm	150mm	41120.00
3227-1004*	50-100mm	50-63mm, 62-75mm, 75-88mm, 87-100mm	Ø62mm, Ø87mm	150mm	54819.00



3227-504

\*帶生產廠檢驗證書

### 數位兩點/三點式內徑測微器



**IP65**  
防塵防水

數據  
傳輸

測微器固定座配夾持塊(選配)



校對環規



6-100mm標配環規  
100-150mm不配環規, 需另購

延長杆(標配)

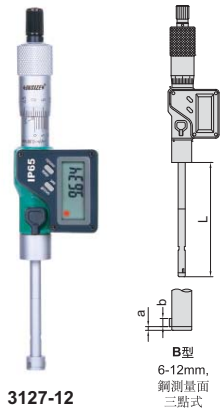

3127-12

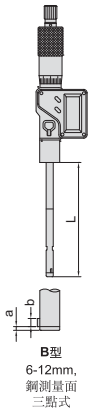

B型  
6-12mm,  
鋼測量面  
三點式



3127-40

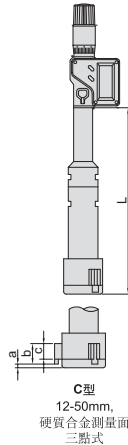

C型  
12-50mm,  
硬質合金測量面  
三點式



3127-125

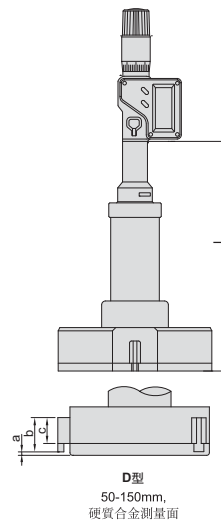

D型  
50-150mm,  
硬質合金測量面  
三點式

- 防塵/防水等級: IP65
- 按鍵: 開/關, 初始值設置, 公/英制轉換, 數據輸出
- 數據傳輸, 自動關機, 棘輪測力
- 可選附件: 數據連接線(型號7315-31需選配接收部, 7302-31), 校對環規(型號6312), 測微器固定座和夾持塊(型號6301和6301-2)

### 單支 (mm)

型號	測定範圍	類型	解析度	精度	校對環規	延長杆(標配)	L	a	b	c	金額
3127-8*	6-8mm/0.24-0.31"	B(三點)	0.001mm/0.00005"	4µm	Ø6(標配)	100	57	1.5	2.5	—	18995.00
3127-10*	8-10mm/0.31-0.39"	B(三點)	0.001mm/0.00005"	4µm	Ø8(標配)	100	57	1.5	2.5	—	18995.00
3127-12*	10-12mm/0.39-0.47"	B(三點)	0.001mm/0.00005"	4µm	Ø10(標配)	100	57	1.5	2.5	—	18995.00
3127-16*	12-16mm/0.47-0.63"	C(三點)	0.001mm/0.00005"	4µm	Ø16(標配)	150	99	0.5	6	4.5	21330.00
3127-20*	16-20mm/0.63-0.79"	C(三點)	0.001mm/0.00005"	4µm	Ø16(標配)	150	99	0.5	6	4.5	21331.00
3127-25*	20-25mm/0.79-0.98"	C(三點)	0.001mm/0.00005"	4µm	Ø25(標配)	150	105	0.5	8	6	22230.00
3127-30*	25-30mm/0.98-1.18"	C(三點)	0.001mm/0.00005"	4µm	Ø25(標配)	150	105	0.5	8	6	22231.00
3127-40*	30-40mm/1.18-1.57"	C(三點)	0.001mm/0.00005"	4µm	Ø40(標配)	150	110	0.5	14	12	24637.00
3127-50*	40-50mm/1.57-1.97"	C(三點)	0.001mm/0.00005"	5µm	Ø40(標配)	150	110	0.5	14	12	24655.00
3127-63*	50-63mm/1.97-2.48"	D(三點)	0.001mm/0.00005"	5µm	Ø62(標配)	150	127	0.5	17.5	14.5	26583.00
3127-75*	62-75mm/2.44-2.95"	D(三點)	0.001mm/0.00005"	5µm	Ø62(標配)	150	127	0.5	17.5	14.5	26872.00
3127-88*	75-88mm/2.95-3.46"	D(三點)	0.001mm/0.00005"	5µm	Ø87(標配)	150	127	0.5	17.5	14.5	27974.00
3127-100*	87-100mm/3.43-3.94"	D(三點)	0.001mm/0.00005"	5µm	Ø87(標配)	150	127	0.5	17.5	14.5	28770.00
3127-125*	100-125mm/3.94-4.92"	D(三點)	0.001mm/0.00005"	6µm	選配	150	175	0.9	29	25	37222.00
3127-150*	125-150mm/4.92-5.91"	D(三點)	0.001mm/0.00005"	6µm	選配	150	175	0.9	29	25	36579.00

### 套裝

型號	測定範圍	包含的測微器	校對環規(標配)	延長杆(標配)	金額
3127-123*	6-12mm	6-8mm, 8-10mm, 10-12mm	Ø6mm, Ø8mm, Ø10mm	100mm	66277.00
3127-202*	12-20mm	12-16mm, 16-20mm	Ø16mm	150mm	35996.00
3127-504*	20-50mm	20-25mm, 25-30mm, 30-40mm, 40-50mm	Ø25mm, Ø40mm	150mm	64140.00
3127-1004*	50-100mm	50-63mm, 62-75mm, 75-88mm, 87-100mm	Ø62mm, Ø87mm	150mm	87156.00

\*帶生產廠檢驗證書



3127-202

### 大量程三點式內徑測微器



- 符合DIN863-4
- 解析度: 0.001mm
- 棘輪測力
- 硬質合金測量面
- 配校對環規

型號	測定範圍	精度	校對環規	金額
3228-70*	50-70mm	5µm	Ø50mm	18679.00
3228-100*	70-100mm	5µm	Ø70mm	24975.00
3228-150*	100-150mm	6µm	Ø100mm	42430.00
3228-250*	150-250mm	8µm	Ø150mm	90660.00

\*帶生產廠檢驗證書



校對環規



3228-70

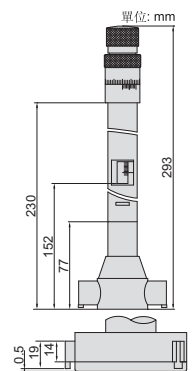

單位: mm

### 數位大量程三點式內徑測微器



- 符合DIN863-4
- 解析度: 0.001mm/0.00005" (其中**3128-300**的解析度為0.001mm/0.0001")
- 防塵/防水等級: IP54
- 按鍵: 開/關, 初始值設置, 公/英制轉換
- 數據傳輸, 自動關機
- 硬質合金測量面, 棘輪測力
- 帶延長杆, 配校對環規(除200-300mm外)
- 可選附件: 數據連接線(型號**7315-30**需選配接收部, **7302-30**)

型號	測定範圍	精度	校對環規	延長杆(標配)	金額
<b>3128-70*</b>	50-70mm/1.97-2.76"	5μm	Ø50mm(標配)	150mm	<b>24325.00</b>
<b>3128-100*</b>	70-100mm/2.76-3.94"	5μm	Ø70mm(標配)	150mm	<b>32321.00</b>
<b>3128-150*</b>	100-150mm/3.94-5.91"	6μm	Ø100mm(標配)	150mm	<b>53715.00</b>
<b>3128-250*</b>	150-250mm/5.91-9.84"	8μm	Ø150mm(標配)	150mm	<b>108979.00</b>
<b>3128-300*</b>	200-300mm/7.87-11.81"	9μm	Ø200mm(選配)	150mm	<b>150386.00</b>

\*帶生產廠檢驗證書

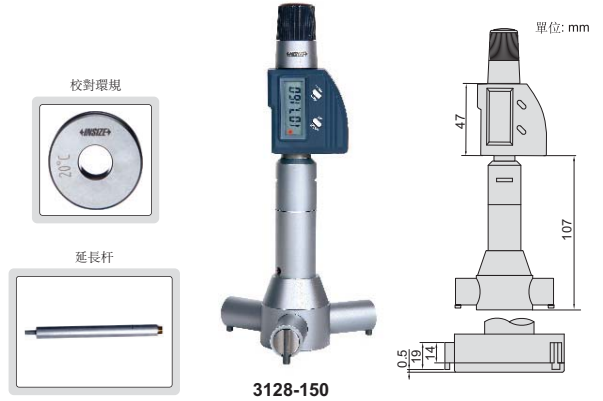

### 槍式三點內徑測微器

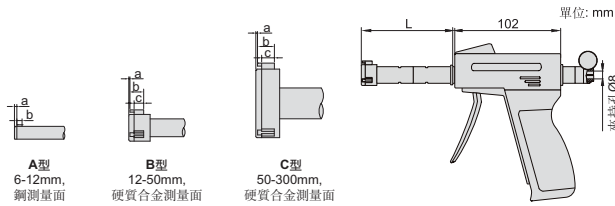

- 可選附件: 數位式量表(型號**2108-101F**, 解析度0.001mm/0.00005"), 校對環規(型號**6312**)

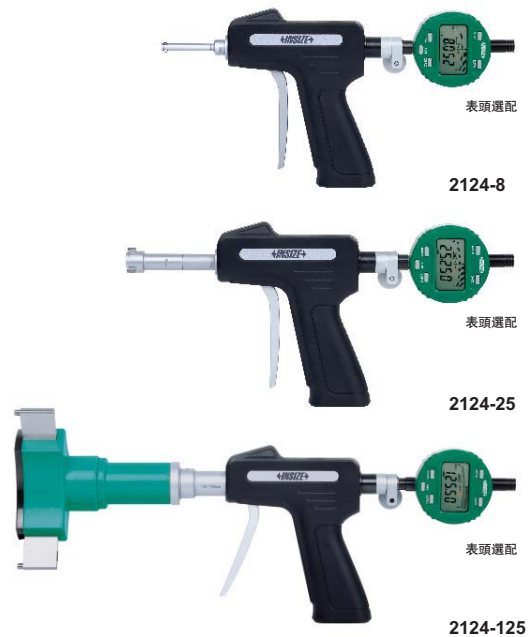

型號	測定範圍	類型	精度(不含表頭)	校對環規	延長杆(標配)	L	a	b	c	金額
<b>2124-8*</b>	6-8mm	A	4μm	Ø6mm(標配)	100mm	50	1.5	2.5	—	<b>18216.00</b>
<b>2124-10*</b>	8-10mm	A	4μm	Ø8mm(標配)	100mm	50	1.5	2.5	—	<b>17873.00</b>
<b>2124-12*</b>	10-12mm	A	4μm	Ø10mm(標配)	100mm	50	1.5	2.5	—	<b>17751.00</b>
<b>2124-16*</b>	12-16mm	B	4μm	Ø16mm(標配)	150mm	65	0.5	6	4.5	<b>17969.00</b>
<b>2124-20*</b>	16-20mm	B	4μm	Ø16mm(標配)	150mm	65	0.5	6	4.5	<b>19010.00</b>
<b>2124-25*</b>	20-25mm	B	4μm	Ø25mm(標配)	150mm	91	0.5	8	6	<b>20220.00</b>
<b>2124-30*</b>	25-30mm	B	4μm	Ø25mm(標配)	150mm	91	0.5	8	6	<b>21500.00</b>
<b>2124-40*</b>	30-40mm	B	4μm	Ø40mm(標配)	150mm	97	0.5	14	12	<b>22850.00</b>
<b>2124-50*</b>	40-50mm	B	5μm	Ø40mm(標配)	150mm	97	0.5	14	12	<b>24320.00</b>
<b>2124-63*</b>	50-63mm	C	5μm	Ø62mm(標配)	150mm	114	0.5	17.5	14.5	<b>26285.00</b>
<b>2124-75*</b>	62-75mm	C	5μm	Ø62mm(標配)	150mm	114	0.5	17.5	14.5	<b>27958.00</b>
<b>2124-88*</b>	75-88mm	C	5μm	Ø87mm(標配)	150mm	114	0.5	17.5	14.5	<b>29774.00</b>
<b>2124-100*</b>	87-100mm	C	5μm	Ø87mm(標配)	150mm	114	0.5	17.5	14.5	<b>31649.00</b>



### 套裝

型號	測定範圍	包含的測微器	校對環規(標配)	延長杆(標配)	金額
<b>2124-S123*</b>	6-12mm	6-8mm, 8-10mm, 10-12mm	Ø6mm, Ø8mm, Ø10mm	100mm	<b>42413.00</b>
<b>2124-S202*</b>	12-20mm	12-16mm, 16-20mm	Ø16mm	150mm	<b>35126.00</b>
<b>2124-S504*</b>	20-50mm	20-25mm, 25-30mm, 30-40mm, 40-50mm	Ø25mm, Ø40mm	150mm	<b>76174.00</b>
<b>2124-S1004*</b>	50-100mm	50-63mm, 62-75mm, 75-88mm, 87-100mm	Ø62mm, Ø87mm	150mm	<b>95323.00</b>

\*帶生產廠檢驗證書



### 千分小孔缸徑規(帶表)

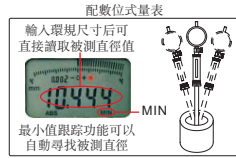

#### 配針盤式表

型號	測定範圍	表頭	精度	重復精度	金額
2853-10	6-10mm	針盤式量表, 型號2313-1FA, 測定範圍1mm, 解析度0.001mm	±0.007mm	0.0015mm	7372.00
2853-18	10-18.5mm		±0.007mm	0.0015mm	7674.00

#### 配數位式量表(數據連接線型號7315-50M需選配接收部, 7302-40M, 選配)

型號	測定範圍	表頭	精度	重復精度	金額
2153-10	6-10mm	數位式量表, 型號2108-101F, 測定範圍12.7mm/0.5", 解析度0.001mm/0.00005"	±0.007mm	0.002mm	16197.00
2153-18	10-18.5mm		±0.007mm	0.002mm	16075.00

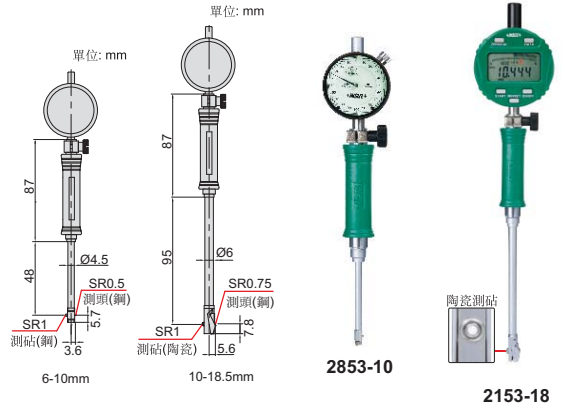

■ 可選附件: 缸徑規設定器, 校對環規(6312系列)

### 百分小孔缸徑規(帶表)

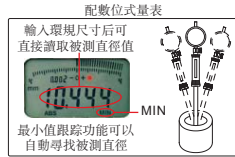
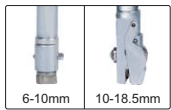

注意: 千分表不適用

#### 配針盤式量表

型號	測定範圍	表頭	精度	重復精度	金額
2852-10	6-10mm	針盤式量表, 型號2311-3F, 測定範圍3mm, 解析度0.01mm	±0.012mm	0.003mm	4854.00
2852-18	10-18.5mm		±0.012mm	0.003mm	4872.00

#### 配數位式量表(數據連接線型號7315-50M需選配接收部, 7302-40M, 選配)

型號	測定範圍	表頭	精度	重復精度	金額
2152-10	6-10mm	數位式量表, 型號2108-10F, 測定範圍12.7mm/0.5", 解析度0.002mm/0.0001" (可切換為: 0.01mm/0.0005")	±0.012mm	0.003mm	12905.00
2152-18	10-18.5mm		±0.012mm	0.003mm	12458.00

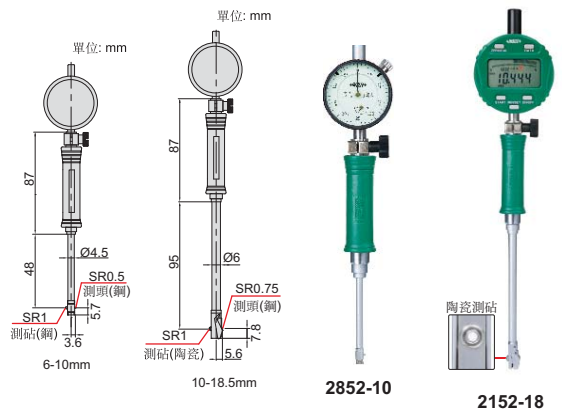

■ 可選附件: 缸徑規設定器, 校對環規(6312系列)

### 千分缸徑規(帶表)

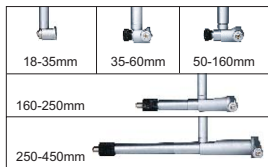
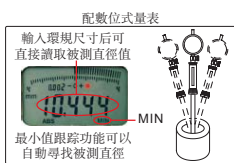

■ 可選附件: 缸徑規設定器, 校對環規(6312系列)

測定範圍	A	B	C	ØD	ØE	F	L
35-60mm	22	9	27	13	12.8	SR2	141
50-100mm	26	9	35	13	12.8	SR2	141
50-160mm	26	9	35	13	12.8	SR2	141
100-160mm	26	9	35	13	12.8	SR2	141
160-250mm	56.5	13	74.5	15	14.5	SR2	241
250-450mm	86.5	15	101.5	15	14.5	SR2.5	241

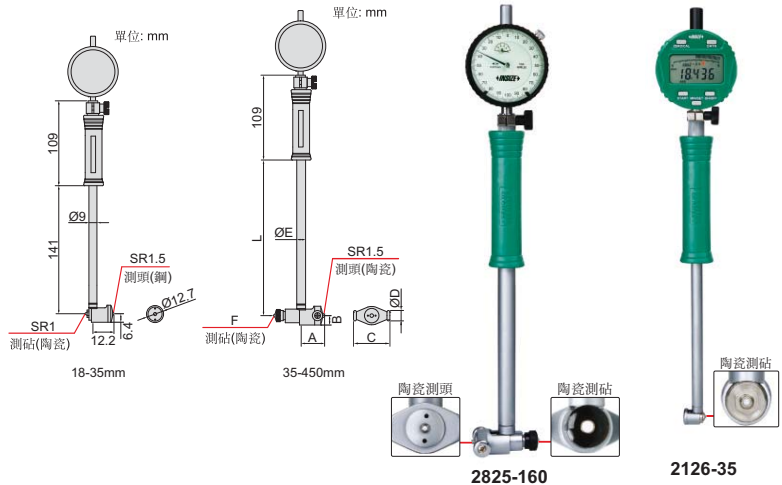

#### 配針盤式量表

型號	測定範圍	表頭	精度	重復精度	金額
2825-35	18-35mm	針盤式量表, 型號2313-1FA, 測定範圍1mm, 解析度0.001mm	±0.007mm	0.0015mm	8276.00
2825-60	35-60mm		±0.007mm	0.0015mm	8287.00
2825-100	50-100mm		±0.007mm	0.0015mm	8136.00
2825-160	50-160mm		±0.007mm	0.0015mm	8299.00
2825-161	100-160mm		±0.007mm	0.0015mm	8297.00
2825-250	160-250mm		±0.007mm	0.0015mm	12553.00
2825-450	250-450mm		±0.007mm	0.0015mm	13768.00

#### 配數位式量表(數據連接線型號7315-50M需選配接收部, 7302-40M, 選配)

型號	測定範圍	表頭	精度	重復精度	金額
2126-35	18-35mm	數位式量表, 型號2108-101F, 測定範圍12.7mm/0.5", 解析度0.001mm/0.00005"	±0.007mm	0.002mm	17028.00
2126-60	35-60mm		±0.007mm	0.002mm	17039.00
2126-100	50-100mm		±0.007mm	0.002mm	16888.00
2126-160	50-160mm		±0.007mm	0.002mm	17130.00
2126-161	100-160mm		±0.007mm	0.002mm	17049.00
2126-250	160-250mm		±0.007mm	0.002mm	21234.00
2126-450	250-450mm		±0.007mm	0.002mm	22546.00

百分缸徑規(帶表)



注意: 千分表  
不適用

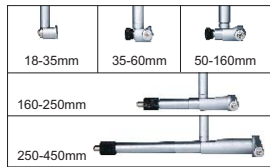
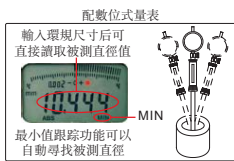
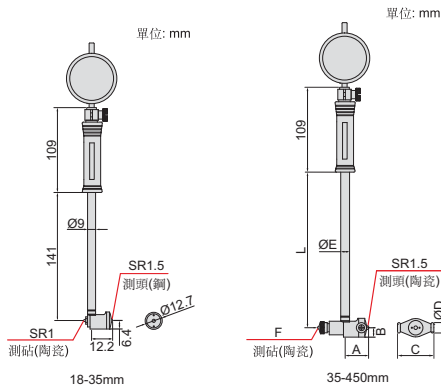

暢銷  
產品

2322-160A

2122-35A

測定範圍	A	B	C	ØD	ØE	F	L
35-60mm	22	9	27	13	12.8	SR2	141
50-100mm	26	9	35	13	12.8	SR2	141
50-160mm	26	9	35	13	12.8	SR2	141
100-160mm	26	9	35	13	12.8	SR2	141
160-250mm	56.5	13	74.5	15	14.5	SR2	241
250-450mm	86.5	15	101.5	15	14.5	SR2.5	241

可選附件: 缸徑規設定器, 校對環規(6312系列), 長手柄(7351系列)

配針盤式量表

型號	測定範圍	表頭	精度	重複精度	金額
2322-35A	18-35mm	針盤式量表, 型號2308-10FA, 測定範圍10mm, 解析度0.01mm	±0.015mm	0.003mm	4726.00
2322-60A	35-60mm		±0.018mm	0.003mm	4750.00
2322-100A	50-100mm		±0.018mm	0.003mm	5412.00
2322-160A	50-160mm		±0.018mm	0.003mm	4922.00
2322-161A	100-160mm		±0.018mm	0.003mm	5604.00
2322-250A	160-250mm		±0.018mm	0.003mm	6765.00
2322-450A	250-450mm		±0.018mm	0.003mm	7909.00

配數位式量表(數據連線型號7315-50M需選配接收部, 7302-40M, 選配)

型號	測定範圍	表頭	精度	重複精度	金額
2122-35A	18-35mm	數位式量表, 型號2108-10F, 測定範圍 12.7mm/0.5", 解析度 0.002mm/0.0001" (可切換為: 0.01mm/0.0005")	±0.015mm	0.003mm	12608.00
2122-60A	35-60mm		±0.018mm	0.003mm	12616.00
2122-160A	50-160mm		±0.018mm	0.003mm	12719.00
2122-250A	160-250mm		±0.018mm	0.003mm	15020.00
2122-450A	250-450mm		±0.018mm	0.003mm	16065.00

大量程百分缸徑規(帶表)

注意: 千分表  
不適用

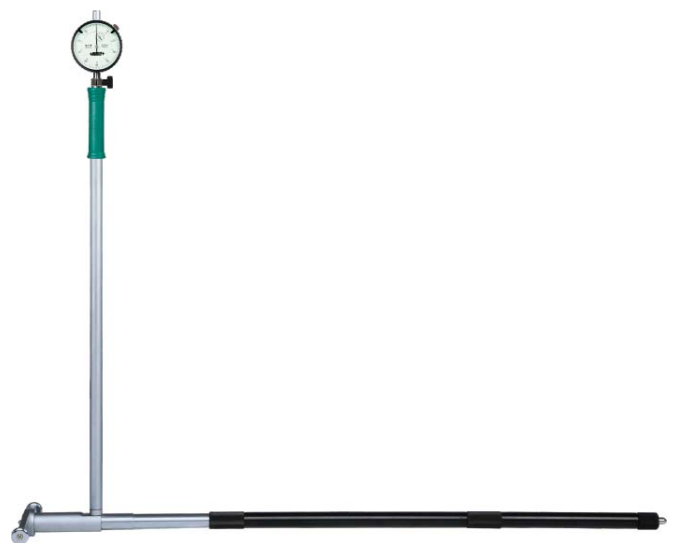
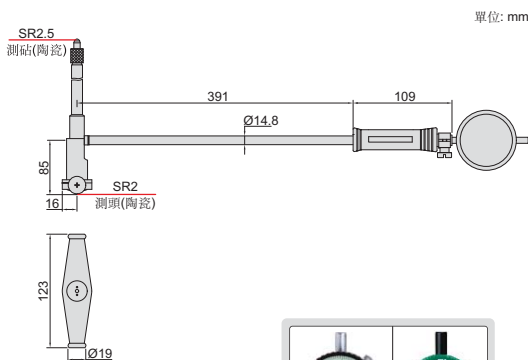

2828-800A

型號	測定範圍	表頭	精度	重複精度	金額
2828-800A	400-800mm	針盤式量表, 型號2308-10FA, 測定範圍10mm, 解析度0.01mm	±0.025mm	0.003mm	11334.00

### 百分缸徑規套裝(帶表)

注意: 千分表  
不適用



2824-S160



包裝(型號2824-S3)

- 可選附件: 校對環規(6312系列), 缸徑規設定器, 長手柄(7351系列)

#### 配針盤式量表

型號	測定範圍	表頭	包含的缸徑規	精度	重複精度	金額
2824-S160	35-160mm	針盤式量表, 型號2308-10FA 測定範圍10mm, 解析度0.01mm	① 35-50mm(不含表頭和手柄) ② 50-160mm	35-50mm ±0.018mm 50-160mm ±0.018mm	0.003mm	6024.00
2824-S3	18-160mm	針盤式量表, 型號2308-10FA 測定範圍10mm, 解析度0.01mm	① 18-35mm ② 35-60mm(不含表頭) ③ 50-160mm(不含表頭)	18-35mm ±0.015mm 35-60mm ±0.018mm 50-160mm ±0.018mm	0.003mm	9744.00

### 缸徑規長手柄

使用方法(加長手柄替換原裝手柄)

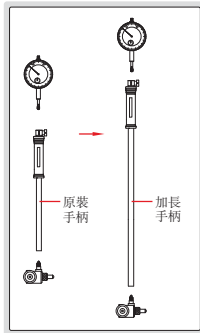

- 用于加大缸徑規測量深度
- 適用於2122, 2322, 2824, 2724, 2127和2827系列缸徑規

型號	適用的缸徑規	A	ØD	類型	金額
7351-EX11	35-60mm, 50-100mm,	475mm	13mm	B	5371.00
7351-EX12		980mm	13mm		6296.00
7351-EX13		50-160mm, 100-160mm	1480mm	14.5mm	A
7351-EX14		1980mm	14.5mm	A	9165.00
7351-EX21	160-250mm, 250-450mm	480mm	14.5mm	B	5697.00
7351-EX22		980mm	14.5mm		6593.00
7351-EX23		1480mm	14.5mm	A	9107.00
7351-EX24		1980mm	14.5mm		9739.00



7351-EX11

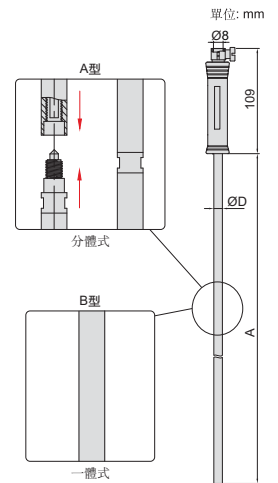

### 缸徑規設定器



可卧式使用

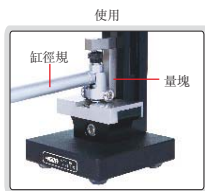

使用

缸徑規 量塊

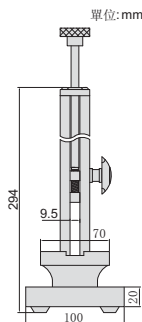

單位:mm



7353-160



視頻

7353-160標配的量塊



- 立式、卧式兩用
- 與量塊一起使用設定缸徑規

型號	設定範圍	重複精度	備注	金額
7353-160	0-160mm	1.2µm	標配量塊	20595.00
7353-160W	0-160mm	1.2µm	不配量塊	15828.00

#### 7353-160標配的量塊

量塊數量	長度(mm)	間隔(mm)	數量(個)	備注
33	1.005	0.01	1	2級 (ISO3650)
	1.01-1.09		9	
	1.1-1.9	0.1	9	
	1-9	1	9	
	10-30	10	3	
	50		1	
	100		1	

### 小孔規套裝

- 每套4支
- 用于小孔、狹縫和凹槽的測量
- 表面鍍鉻

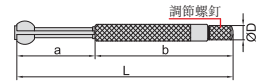
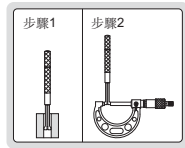

型號	總測定範圍	包含的小孔規	金額
4208-1	3-13mm	3-5mm, 5-7.5mm, 7.5-10mm, 10-13mm	754.00

測定範圍	L	a	b	ØD
3-5mm	76mm	24mm	52mm	5mm
5-7.5mm	79mm	27mm	52mm	5mm
7.5-10mm	88mm	30mm	58mm	6mm
10-13mm	91mm	34mm	58mm	6mm

4208-1

### 伸縮規套裝

- 每套6支
- 用于快速測量孔內徑和槽寬
- 表面鍍鉻

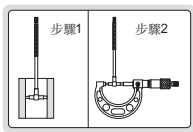

測定範圍	L	Øa	Øb	Øc
8-12.7mm	115mm	3.9mm	2.9mm	6.2mm
12.7-19mm	115mm	5.3mm	3.8mm	6.2mm
19-32mm	115mm	5.3mm	3.8mm	6.2mm
32-54mm	137mm	7.6mm	6.1mm	7.2mm
54-90mm	137mm	7.6mm	6.1mm	7.2mm
90-150mm	137mm	7.6mm	6.1mm	7.2mm

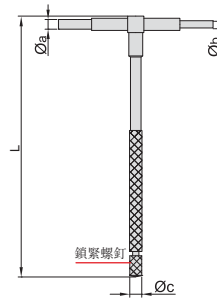

型號	總測定範圍	包含的伸縮規	金額
4206-1	8-150mm	8-12.7mm, 12.7-19mm, 19-32mm, 32-54mm, 54-90mm, 90-150mm	2198.00

4206-1

### 長手柄伸縮規

- 用于測量深孔內徑和深槽寬度
- 表面鍍鉻

型號	測定範圍	L	Øa	Øb	Øc	金額
4209-1	8-12.7mm	300mm	3.9mm	2.9mm	6.2mm	427.00
4209-2	12.7-19mm	300mm	5.3mm	3.8mm	6.2mm	429.00
4209-3	19-32mm	300mm	5.3mm	3.8mm	6.2mm	430.00
4209-4	32-54mm	300mm	7.6mm	6.1mm	7.2mm	483.00
4209-5	54-90mm	300mm	7.6mm	6.1mm	7.2mm	482.00
4209-6	90-150mm	300mm	7.6mm	6.1mm	7.2mm	496.00

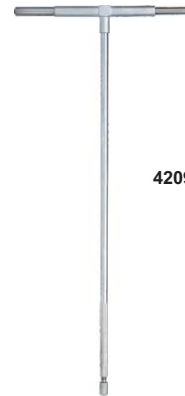
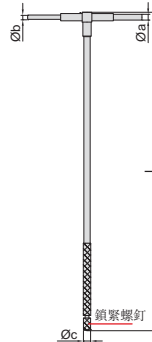

4209-6

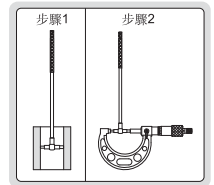

### 圓周尺

可定制

- 用于測量管子、樹和輪胎等的外徑和外圓周長
- 不銹鋼尺身

型號	圓周測定範圍	直徑測定範圍	解析度	精度		金額
				圓周測量	直徑測量	
7136-940	160-940mm	Ø50-300mm	0.1mm	±0.30mm	±0.10mm	6053.00
7136-1880	940-1880mm	Ø300-600mm	0.1mm	±0.30mm	±0.10mm	6711.00
7136-2830	1880-2830mm	Ø600-900mm	0.1mm	±0.30mm	±0.10mm	7370.00
7136-3770	2830-3770mm	Ø900-1200mm	0.1mm	±0.30mm	±0.10mm	7864.00
7136-4710	3770-4710mm	Ø1200-1500mm	0.1mm	±0.30mm	±0.10mm	8358.00
7136-5650	4710-5650mm	Ø1500-1800mm	0.1mm	±0.30mm	±0.10mm	8852.00
7136-6600	5650-6600mm	Ø1800-2100mm	0.1mm	±0.30mm	±0.10mm	9346.00
7136-7540	6600-7540mm	Ø2100-2400mm	0.1mm	±0.30mm	±0.10mm	9840.00
7136-8480	7540-8480mm	Ø2400-2700mm	0.1mm	±0.30mm	±0.10mm	10334.00
7136-9430	8480-9430mm	Ø2700-3000mm	0.1mm	±0.30mm	±0.10mm	10827.00



7136-1880

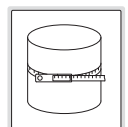
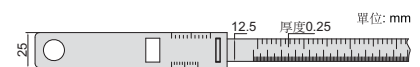



## 外徑尺

可定制

- 用于測量管子、輪胎等的外徑
- 不銹鋼尺身

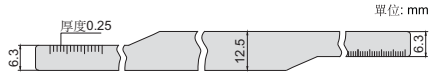

7135-525

型號	直徑測定範圍	解析度	精度	金額
7135-35*	Ø20-35mm	0.05mm	±0.05mm	1229.00
7135-55*	Ø30-55mm	0.05mm	±0.05mm	1559.00
7135-125	Ø50-125mm	0.01mm	±0.05mm	1725.00
7135-225	Ø100-225mm	0.01mm	±0.05mm	2056.00
7135-375	Ø200-375mm	0.01mm	±0.05mm	2553.00
7135-525	Ø350-525mm	0.01mm	±0.05mm	2886.00
7135-725	Ø500-725mm	0.01mm	±0.06mm	3385.00
7135-925	Ø700-925mm	0.01mm	±0.06mm	3719.00
7135-1125	Ø900-1125mm	0.02mm	±0.06mm	4217.00
7135-1325	Ø1100-1325mm	0.02mm	±0.08mm	4550.00
7135-1525	Ø1300-1525mm	0.02mm	±0.08mm	5050.00
7135-1725	Ø1500-1725mm	0.02mm	±0.08mm	5383.00
7135-1925	Ø1700-1925mm	0.02mm	±0.08mm	5883.00
7135-2125	Ø1900-2125mm	0.02mm	±0.08mm	6216.00
7135-2325	Ø2100-2325mm	0.02mm	±0.10mm	6714.00
7135-2525	Ø2300-2525mm	0.02mm	±0.10mm	7048.00
7135-2750	Ø2500-2750mm	0.02mm	±0.10mm	7547.00
7135-3000	Ø2750-3000mm	0.02mm	±0.10mm	8045.00
7135-3250	Ø3000-3250mm	0.02mm	±0.15mm	8708.00
7135-3500	Ø3250-3500mm	0.02mm	±0.15mm	9372.00

\*有此標示的型號厚度為0.10mm, 其余型號厚度為0.25mm

型號	直徑測定範圍	解析度	精度	金額
7135-3750	Ø3500-3750mm	0.02mm	±0.15mm	10037.00
7135-4000	Ø3750-4000mm	0.02mm	±0.20mm	10866.00
7135-4250	Ø4000-4250mm	0.02mm	±0.20mm	11693.00
7135-4500	Ø4250-4500mm	0.02mm	±0.20mm	12521.00
7135-4750	Ø4500-4750mm	0.02mm	±0.20mm	13348.00
7135-5000	Ø4750-5000mm	0.02mm	±0.20mm	14505.00
7135-5250	Ø5000-5250mm	0.02mm	±0.005%L**	15498.00
7135-5500	Ø5250-5500mm	0.02mm	±0.005%L**	16655.00
7135-5750	Ø5500-5750mm	0.02mm	±0.005%L**	17648.00
7135-6000	Ø5750-6000mm	0.02mm	±0.005%L**	18641.00
7135-6250	Ø6000-6250mm	0.02mm	±0.005%L**	19632.00
7135-6500	Ø6250-6500mm	0.02mm	±0.005%L**	20625.00
7135-6750	Ø6500-6750mm	0.02mm	±0.005%L**	21618.00
7135-7000	Ø6750-7000mm	0.02mm	±0.005%L**	22611.00
7135-7250	Ø7000-7250mm	0.02mm	±0.005%L**	23603.00
7135-7500	Ø7250-7500mm	0.02mm	±0.005%L**	24595.00
7135-7750	Ø7500-7750mm	0.02mm	±0.005%L**	25588.00
7135-8000	Ø7750-8000mm	0.02mm	±0.005%L**	26580.00
7135-8250	Ø8000-8250mm	0.02mm	±0.005%L**	27573.00

\*\*L是實際測量值(單位mm)

## 圓周尺(經濟型)

- 用于測量管子、樹和輪胎等的直徑和圓周
- 激光刻線
- 不銹鋼尺身

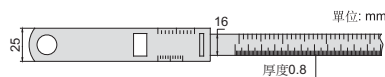

7114-950

型號	圓周測定範圍	直徑測定範圍	解析度	精度		金額
				圓周測量	直徑測量	
7114-950	150-950mm	Ø50-300mm	0.1mm	±3mm	±1mm	659.00
7114-2200	940-2200mm	Ø300-700mm	0.1mm	±3mm	±1mm	811.00
7114-3460	2190-3460mm	Ø700-1100mm	0.1mm	±3mm	±1mm	1100.00

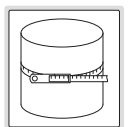

## 柔性內徑尺

- 用于測量柔性材料的平均內徑
- PET材質



7137-60

型號	直徑測定範圍	解析度	精度	金額
7137-30	Ø10-30mm	0.05mm	±0.10mm	449.00
7137-60	Ø30-60mm	0.05mm	±0.10mm	805.00
7137-100	Ø50-100mm	0.05mm	±0.10mm	988.00
7137-200	Ø100-200mm	0.05mm	±0.10mm	1165.00
7137-350	Ø200-350mm	0.05mm	±0.15mm	1521.00

